

## DETAILED PARTS AND ASSEMBLY PROCEDURE

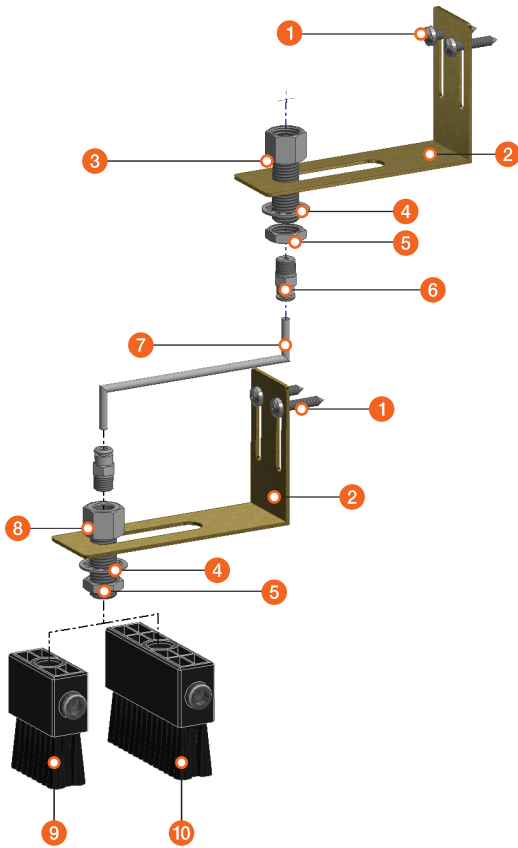

LIST	PART No.	DESCRIPTION	Q'TY
1	B051	Self Drilling Screw, #8 x 19, Steel	4
2	B003-01	Oil Brush Bracket, "L" Shape, Steel	2
3	A314	Reducer, PF1/4" F x PF1/4" Mx30mm x PT1/8" F, Steel	1
4	B058	Tooth Washer, O.D.23mm x I.D.14.5mm x 1t, Steel	2
5	N001	Nut, PF1/4" F x 5mm, Steel	2
6	A317	One-Touch fitting, Ø4 x PT1/8" M, Nickel Plated	2
7	C021-1	Nylon Tube, 3m (10ft) O.D. 4mm x I.D. 2.5mm	1
8	A316	Reducer, PT1/8" F x PF1/4" M x 25mm Adaptor, Steel	1
9	C017	Oil Brush, 45 x 20 x 30mm Flat Nylon, PF1/4" F	1
10	C018	Oil Brush, 74 x 20 x 30mm Flat Nylon, PF1/4" F	1

### ASSEMBLY PROCEDURE

1. Install the Oil Brush Bracket ( 2 ) in an appropriate location using the Self Drilling screws ( 1 ).
2. Fasten the Reducer ( 3 ), the tooth washer ( 4 ), Nut ( 5 ) and One-Touch fitting ( 6 ).
3. Install another Oil Brush Bracket ( 2 ) in an appropriate location using the Self Drilling screw ( 1 ) to remote install.
4. Fasten the Tooth washer ( 4 ), Nut ( 5 ), Reducer ( 8 ) and One-Touch fitting ( 6 ). Connect each end of the Nylon Tube ( 7 ) to both One-Touch fittings ( 6 ).
5. Connect the appropriate brush ( 9 ) or ( 10 ) to the thread of the Reducer ( 8 ).

### COMMENTS

Output volume may vary depending on oil viscosity, ambient temperature, etc.

LIST & PART No.	KIT No.	DESCRIPTION
[ 1 ~ 8 ] + 9 (C017)	<b>C042</b>	[EO] Remote Installation & 45mm Oil Brush Kit
[ 1 ~ 8 ] + 10 (C018)	<b>C043</b>	[EO] Remote Installation & 74mm Oil Brush Kit